

Notes

- 1. All Burrs & Sharp edges must be removed
- 2. All Dimensions Are Prior To Adding a Finish

WELDING: Yes - See Detail		HANG LOCATION: None Specific					
SPECIFIC TAG LOCATION: No		PEM BEFORE FOLDING: NO					
FINISH: Satin Black Powder		MATERIAL: 1.5mm Mild Steel		ONE	01/04/2022	EAT	2mm Offset Added Between box/hood.
SCALE: 1:3.5	DRAWN BY: EAT		MOD NO.	DATE	BY	MODIFICATION	
SHEET 1 OF 2	CHECKED BY:		TITLE: X915XS Hood				
PROJECT NO: 1404	DATE: 24/03/2022		DRG NO: CIE0013				

TOLERANCES UNLESS OTHERWISE STATED: * DENOTES A DIMENSION ON CENTRE LINE WITH A POSITIONAL TOLERANCE OF 50% OF THE DIMENSION TOLERANCE

WHOLE NUMBERS	I.E. 35	±0.5mm
ONE DECIMAL	I.E. 35.1	±0.2mm
TWO DECIMALS	I.E. 35.10	±0.1mm
ANGULAR		±0.5°

ALL DIMENSIONS ARE IN mm
DO NOT SCALE FROM THIS DRAWING IF IN DOUBT - ASK



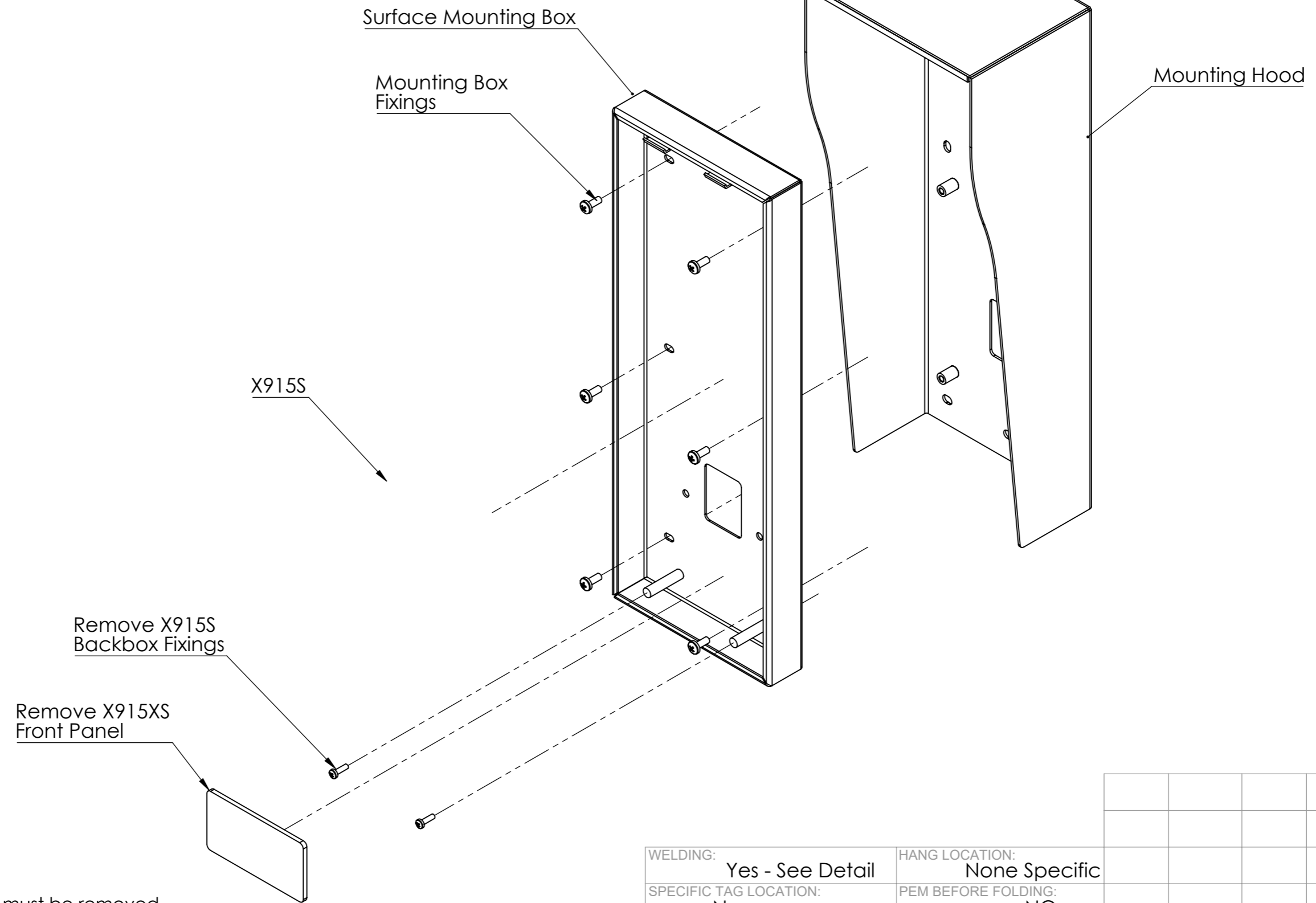

Notes

- 1. All Burrs & Sharp edges must be removed
- 2. All Dimensions Are Prior To Adding a Finish

WELDING: Yes - See Detail	HANG LOCATION: None Specific				
SPECIFIC TAG LOCATION: No	PEM BEFORE FOLDING: NO				
FINISH: Satin Black Powder	MATERIAL: 1.5mm Mild Steel	ONE	01/04/2022	EAT	2mm Offset Added Between box/hood.
SCALE: 1:2.5	DRAWN BY: EAT	MOD NO.	DATE	BY	MODIFICATION
SHEET 2 OF 2	CHECKED BY:	TITLE: X915XS Hood			
PROJECT NO: 1404	DATE: 24/03/2022	DRG NO: CIE0013			



TOLERANCES UNLESS OTHERWISE STATED:
 * DENOTES A DIMENSION ON CENTRE LINE WITH A POSITIONAL TOLERANCE OF 50% OF THE DIMENSION TOLERANCE
 ALL DIMENSIONS ARE IN mm
 DO NOT SCALE FROM THIS DRAWING IF IN DOUBT - ASK

WHOLE NUMBERS	I.E. 35	±0.5mm
ONE DECIMAL	I.E. 35.1	±0.2mm
TWO DECIMALS	I.E. 35.10	±0.1mm
ANGULAR		±0.5°

